

18-Line SCSI Terminator

FEATURES

- Complies with SCSI, SCSI-2, SCSI-3 and FAST-20 Standards
- 2pF Channel Capacitance During Disconnect
- 50µA Supply Current in Disconnect Mode
- 110 Ohm Termination
- SCSI Hot Plugging Compliant, 10nA Typical
- +400mA Sinking Current for Active Negation
- -650mA Sourcing Current for Termination
- Trimmed Impedance to 5%

DESCRIPTION

The UCC5618 provides 18 lines of active termination for a SCSI (Small Computers Systems Interface) parallel bus. The SCSI standard recommends and Fast-20 (Ultra) requires active termination at both ends of the cable.

Pin for pin compatible with the UC5601 and UC5608, the UCC5618 is ideal for high performance 5V SCSI systems, Tempwr 4.0-5.25V. During disconnect the supply current is only 50µA typical, which makes the IC attractive for lower powered systems.

The UCC5618 is designed with a low channel capacitance of 2pF, which eliminates effects on signal integrity from disconnected terminators at interim points on the bus.

The power amplifier output stage allows the UCC5618 to source full termination current and sink active negation current when all termination lines are actively negated.

The UCC5618, as with all Unitrode terminators, is completely hot pluggable and appears as high impedance at the terminating channels with TRMPWR=0V or open.

Internal circuit trimming is utilized, first to trim the 110 ohm impedance, and then most importantly, to trim the output current as close to the max SCSI-3 spec as possible, which maximizes noise margin in fast SCSI operation.

Other features include thermal shutdown and current limit.

This device is offered in low thermal resistance versions of the industry standard 28 pin wide body SOIC, TSSOP and PLCC.

BLOCK DIAGRAM

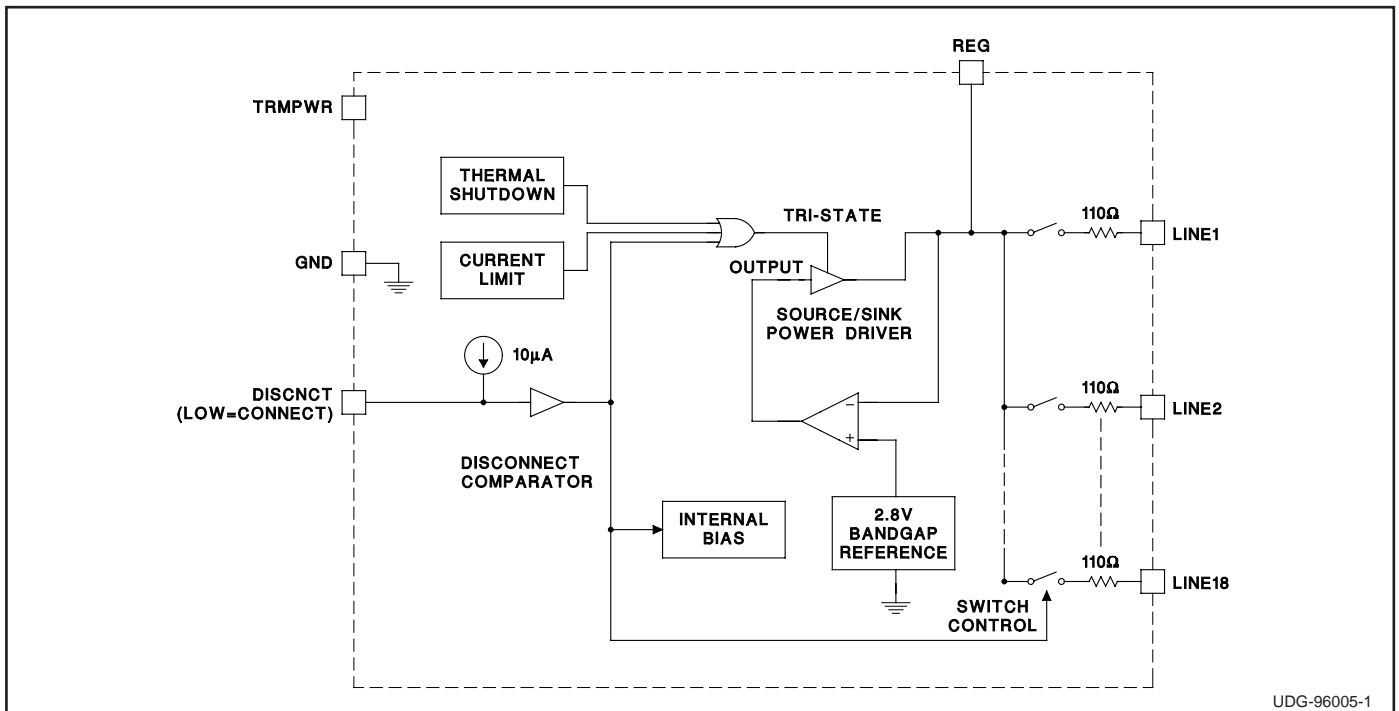

UDG-96005-1

Circuit Design Patented

ABSOLUTE MAXIMUM RATINGS

Tempwr	+7V
Signal Line Voltage0V to +7V
Regulator Output Current1A
Storage Temperature	-65°C to +150°C
Operating Junction Temperature	-55°C to +150°C
Lead Temperature (Soldering, 10 Seconds)300°C

All currents are positive into, negative out of the specified terminal. Consult Packaging Section of Databook for thermal limitations and considerations of packages.

CONNECTION DIAGRAMS

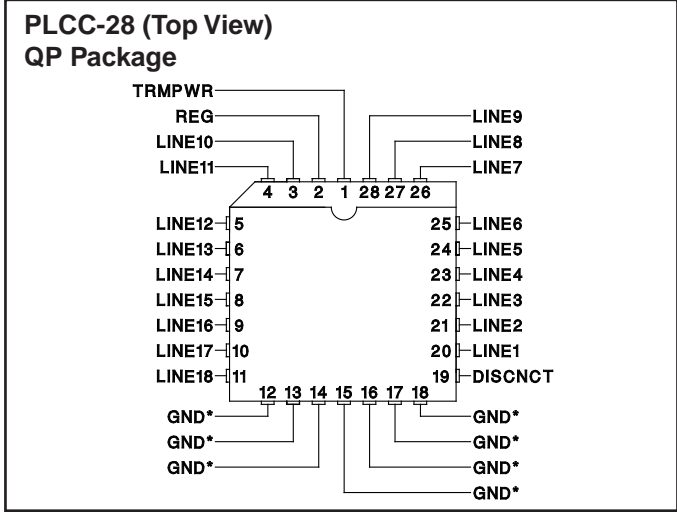

* DWP package pins 12 - 18 serve as both heatsink and signal ground.

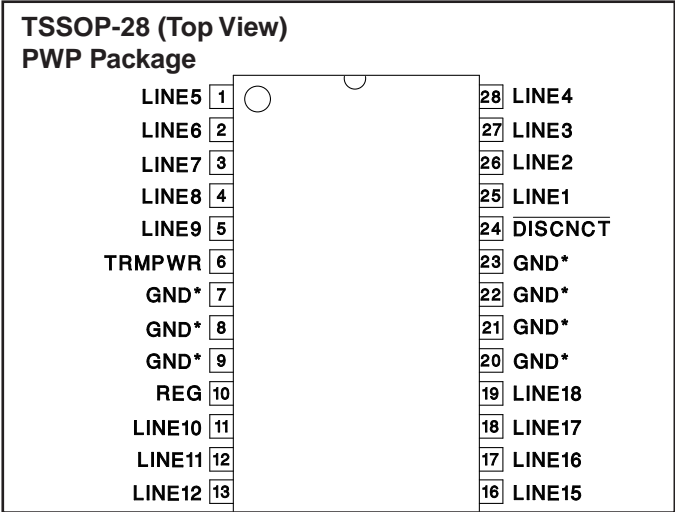

* PWP package pin 23 serves as signal ground; pins 7, 8, 9, 20, 21, and 22 serve as heatsink ground.

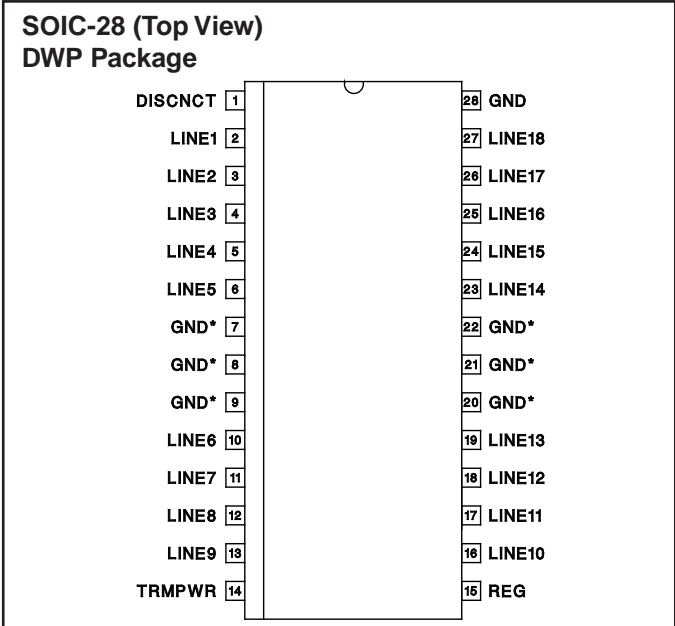
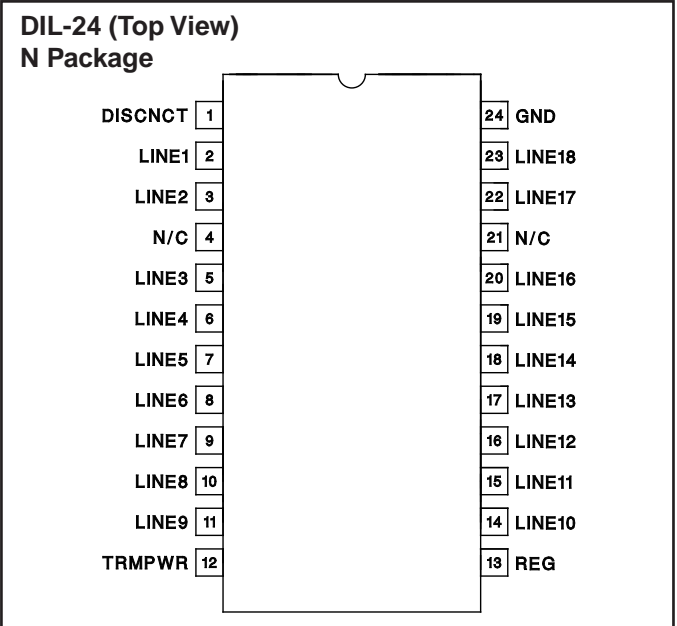

* DWP package pin 28 serves as signal ground; pins 7, 8, 9, 20, 21, 22 serve as heatsink/ground.
Note: Drawings are not to scale.

ELECTRICAL CHARACTERISTICS Unless otherwise stated these specifications apply for TA = 0°C to 70°C, TRMPWR = 4.75V, DISCNCT = 0V, TA = TJ.

PARAMETER	TEST CONDITIONS	MIN	TYP	MAX	UNITS
Supply Current Section					
Tempwr Supply Current	All termination lines = Open		1	2	mA
	All termination lines = 0.2V		420	440	mA
Power Down Mode	DISCNCT = TRMPWR		50	100	µA
Output Section (Termination Lines)					
Termination Impedance	See Figure 1	104.5	110	115.5	Ω
Output High Voltage	VTRMPWR = 4V (Note 1)	2.6	2.8	3	V
Max Output Current	VLINE = 0.2V, TJ = 25°C	-22.1	-23.3	-24	mA
	VLINE = 0.2V	-20.7	-23.3	-24	mA
	VLINE = 0.2V, TRMPWR = 4V, TJ = 25°C (Note 1)	-21	-23.3	-24	mA
	VLINE = 0.2V, TRMPWR = 4V (Note 1)	-20	-23	-24	mA
	VLINE = 0.5V			-22.4	mA
Output Leakage	DISCNCT = 2.4V, TRMPWR = 0V to 5.25V, REG = 0.2V, VLINE = 5.25V		10	400	nA
Output Capacitance	DISCNCT = 2.4V (Note 2)		2	3.5	pF
Regulator Section					
Regulator Output Voltage		2.6	2.8	3	V
Drop Out Voltage	All Termination Lines = 0.2V		0.4	0.8	V
Short Circuit Current	VREG = 0V	-475	-650	-850	mA
Sinking Current Capability	VREG = 3.5V	200	400	800	mA
Thermal Shutdown			170		°C
Thermal Shutdown Hysteresis			10		°C
Disconnect Section					
Disconnect Threshold		0.8	1.5	2	V
Input Current	DISCNCT = 0V		-10	-30	µA

Note 1: Measuring each termination line while other 17 are low (0.2V).
 Note 2: Guaranteed by design. Not 100% tested in production.

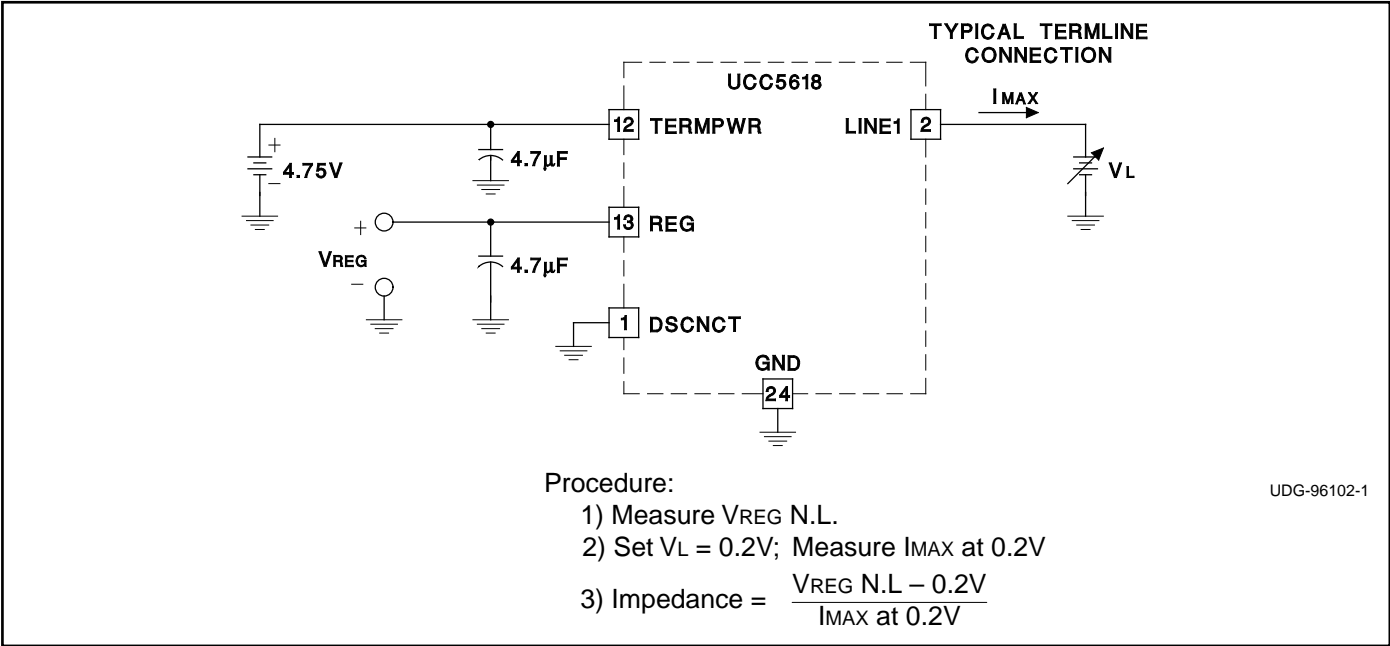

Figure 1. Termline Impedance Measurement Circuit

PIN DESCRIPTIONS

DISCNCT: Taking this pin high or leaving it open causes the 18 channels to become high impedance and the chip to go into low-power mode; a low state allows the channels to provide normal termination.

GND: Ground reference for the IC.

LINE1-18: 110 ohm termination channels.

REG: Output of the internal 2.8V regulator.

TRMPWR: Power for the IC.

APPLICATION INFORMATION

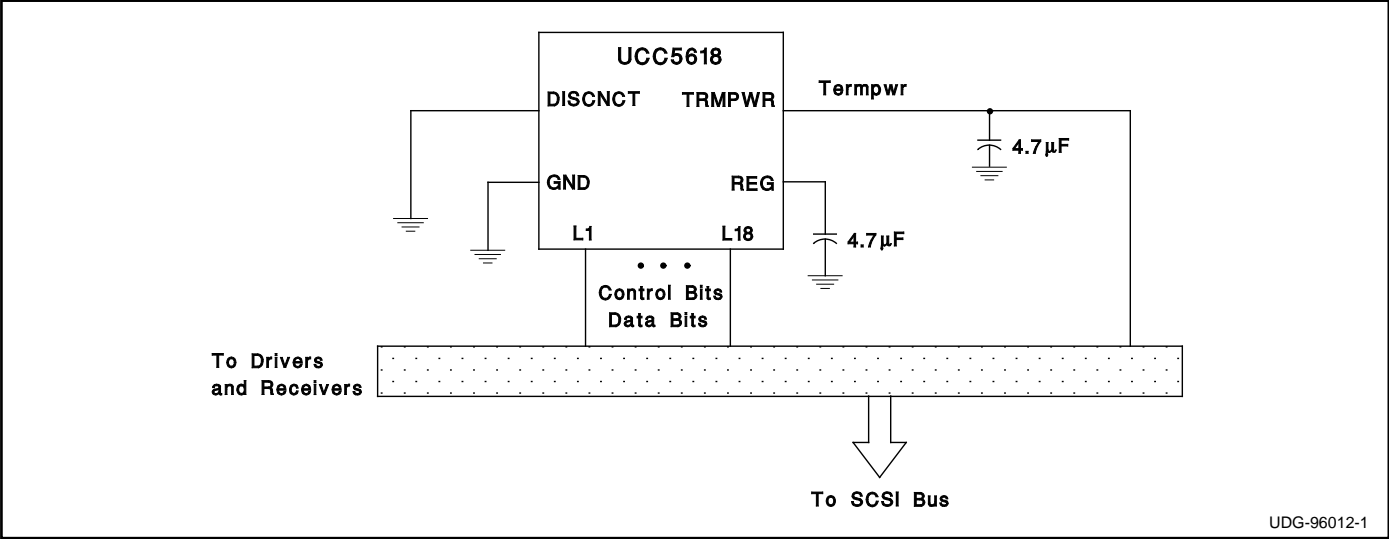

UDG-96012-1